

MICRO/LEVEL® Isolators for Stamping Presses & Machine Tools

Series 9 to 26



*Your best way to install and level machines
for effective control of vibration and noise*



MICRO/LEVEL® Isolators for Fast, Easy and

Since 1964, VIBRO/DYNAMICS Corporation has been providing high quality vibration isolators and machine mounts for stamping presses and machine tools. Our simple approach has been to offer superior products with unmatched customer service and engineering support.

Our 9 to 26 Series Micro/Level® Isolators are made from high-quality materials: ductile-iron support housings; high-strength steel bearing plates and leveling screws; and one piece, specially compounded, compression molded elastomers that last!



Elastomer shape, thickness, and durometer are changed to obtain the desired stiffness characteristics.

Our elastomeric cushions are unsurpassed in the industry and help to separate us from the competition. Every elastomer is compression molded from high-quality, specially compounded polymers. These sturdy, homogenous elastomers are one piece and do not rely on separate inserts to adjust stiffness and to boost load ratings. Stiff inserts cause concentrated load distributions that affect proper support and elastomer stability. The high stiffness of the inserts also reduce vibration isolation performance. For flexibility in applying isolators, Vibro/Dynamics relies instead on a variety of elastomer stiffnesses available in each size. The isolator stiffness properties are varied by changing the durometer, thickness and shape of the elastomer, resulting in superior performance.

The chart shows actual vibration measurements taken from a 400 ton stamping press. This press was originally installed on a set of competitor mounts. The customer was experiencing vibration transmission problems that could not be solved by the competitor after repeated requests.

Vibro/Dynamics Application Engineers reviewed the press application, found nothing unusual about the press application, and selected a set of Micro/Level® Isolators that best matched the press and its operating characteristics.

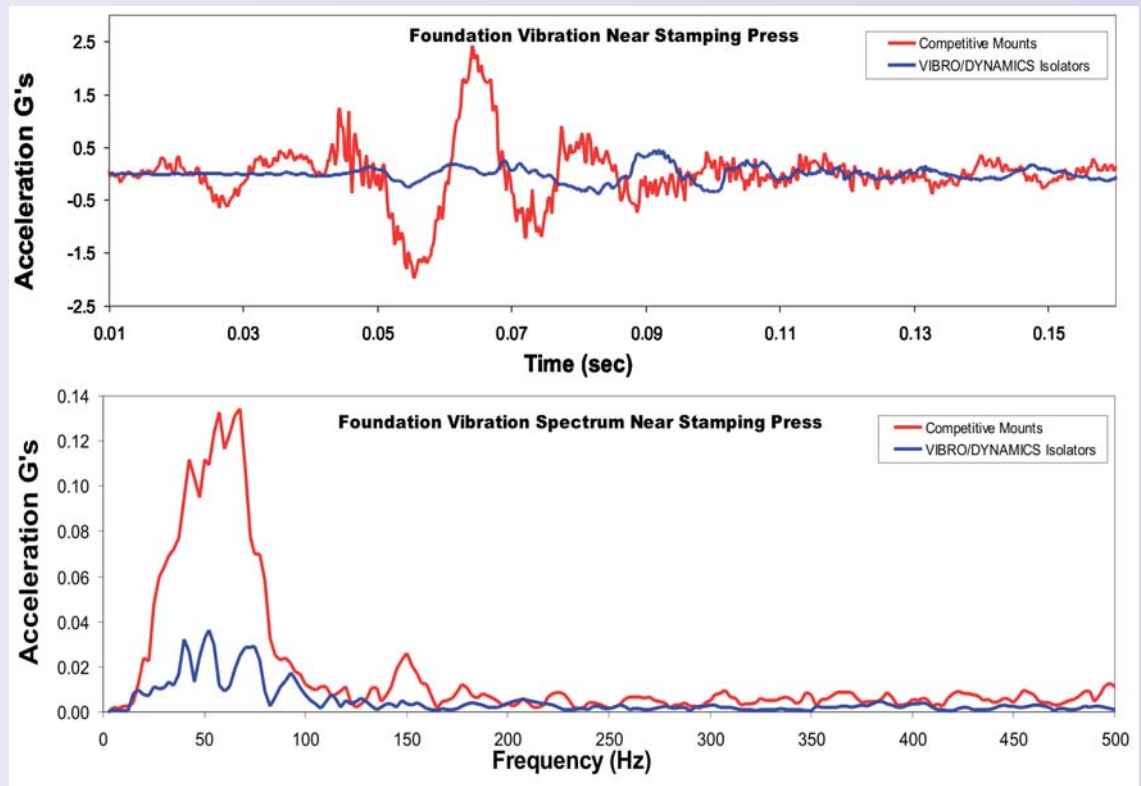

The measurements showed that the Vibro/Dynamics® Micro/Level Isolators provided an additional 80% isolation over the competitor's mounts. The customer's vibration transmission problem was solved quickly!



Economical Installations.

Superior Elastomer Properties

- Low creep
- High resiliency
- Excellent chemical resistance
- High safety factor

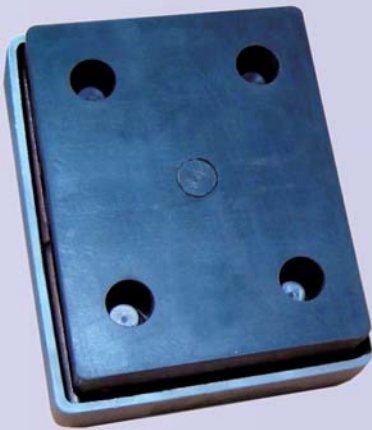

Specially compounded, one-piece, elastomers ensure unmatched isolation performance and proper support.

Faster, Easier Installation

Micro/Level Isolators eliminate the need for anchor bolts, shims, and grout. In most cases, no special foundations are required, getting you into production faster with minimum installation costs.

Vibration Control

Actual field tests showed that transmitted vibration can be reduced up to 98% over hard-mounting with Micro/Level Isolators, improving machine performance, product quality, and protecting sensitive equipment and neighbors.

And, in head-to-head vibration measurements taken on a 400 ton blanking press, Vibro/Dynamics Isolators provided an additional 80% isolation over Competitive Mounts.

Precision Leveling and Alignment

The Micro/Level Isolator design makes precision leveling adjustments fast and easy. The isolator's leveling screw provides far greater leveling accuracy than shims or grout. Machinery relocations are just as fast, and if your floor or foundation should settle, releveling adjustments can be made with a simple turn of the wrench.

Proper Machine Support - Fine/Tuning

Precision leveling is critical to proper machine support. A machine can be level, yet not properly supported. Fine/Tuning is a process of making small, precise adjustments using the isolator's leveling screw to provide precise machine support. Fine/Tuning eliminates machine bed twist caused by improper support. Benefits include improved part quality, repeatability, and increased machine and tooling life.

Noise Reduction

A reduction in vibration results in a decrease in structural-borne noise. Noise reductions of 6.5 dB have been achieved using Micro/Level Isolators. Improved working conditions and reduced neighbor complaints are obvious benefits.

Meets OSHA Anchoring Requirements

The custom-engineered elastomers in Micro/Level Isolators offer an excellent coefficient of friction to eliminate machine walking to meet OSHA anchoring requirements.

TYPICAL APPLICATIONS

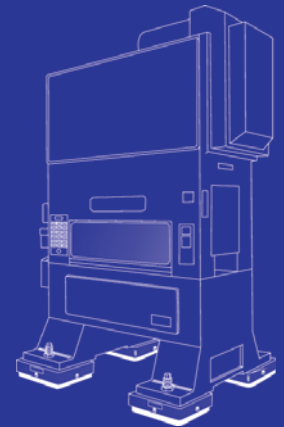

Metalworking Presses
 Mechanical
 Hydraulic
 Pneumatic
 Forging
 Turret Punch
 Gap Frame
 Straight-side
 Press Brakes
 Shears

Precision Machine Tools

Machining Centers
 Grinders
 Transfer Lines
 Milling Machines
 Cold Headers
 Drills
 Lathes
 Grinders
 Saws
 Upsetters

Die Cast Machines

Plastic Injection Molders

Metal Container
 Bodymakers
 Wall-Ironers
 Necker Flangers
 Decorators and Fillers

Other Applications

Pumps
 Textile Machinery
 Generators
 Transformers
 Woodworking Equipment

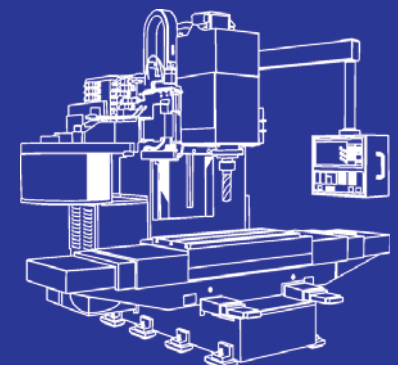

VIBRO/DYNAMICS MICRO/LEVEL® ISOLATORS

SPECIFICATIONS

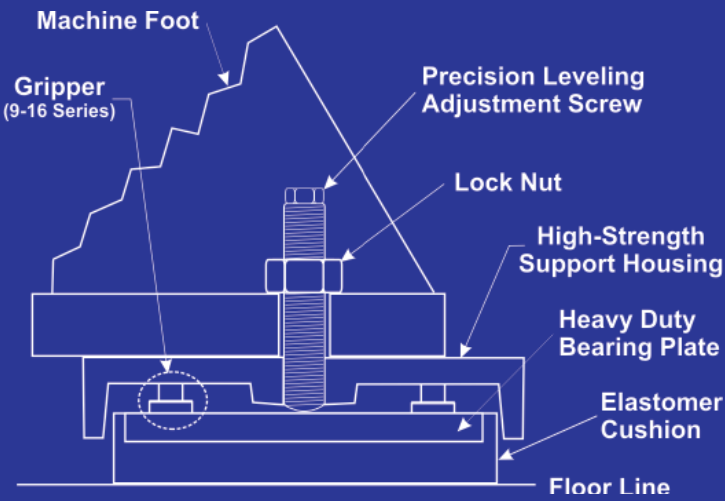

Micro/Level® Isolator		Isolator Dimensions (inch)				Leveling Screw Diameter	
Series	Model	Length	Width	Height		Minimum	Maximum
				Minimum	Maximum		
9	9K	10 1/4	8 1/4	2 3/4	3 1/2	5/8	1 1/8
9	9L	10 1/4	8 1/4	3 1/8	3 7/8	5/8	1 1/8
9	9M	10 1/4	8 1/4	3 3/4	4 1/2	5/8	1 1/8
10	10K	12 1/8	10 1/8	3 1/4	4	3/4	1 1/4
10	10L	12 1/8	10 1/8	3 3/8	4 1/8	3/4	1 1/4
10	10M	12 1/8	10 1/8	4	4 3/4	3/4	1 1/4
12	12K	12 1/4	10 1/4	4 1/8	4 7/8	1	1 3/4
12	12L	12 1/4	10 1/4	4 1/4	5	1	1 3/4
12	12M	12 1/4	10 1/4	4 7/8	5 5/8	1	1 3/4
16	16K	16 1/4	13 1/4	5	6	1 1/2	2 3/4
16	16L	16 1/4	13 1/4	5	6	1 1/2	2 3/4
16	16M	16 1/4	13 1/4	5 3/4	6 3/4	1 1/2	2 3/4
20	BFM1230	20 1/2	14 1/2	7	8	2	3 1/2
20	BFM1150	20 1/2	14 1/2	6 3/8	7 3/8	2	3 1/2
20	BFM1340	20 1/2	14 1/2	6	7	2	3 1/2
26	BFM2660	26 1/2	19 1/2	8 3/4	9 3/4	2	3 1/2
26	BFM2676	26 1/2	19 1/2	8 3/4	9 3/4	2	3 1/2
26	BFM2690	26 1/2	19 1/2	8 3/4	9 3/4	2	3 1/2
26	BFM26100	26 1/2	19 1/2	8 1/4	9 1/4	2	3 1/2
26	BFM26110	26 1/2	19 1/2	8 1/4	9 1/4	2	3 1/2
26	BFM26135	26 1/2	19 1/2	8 1/4	9 1/4	2	3 1/2

Thousands of successful installations worldwide

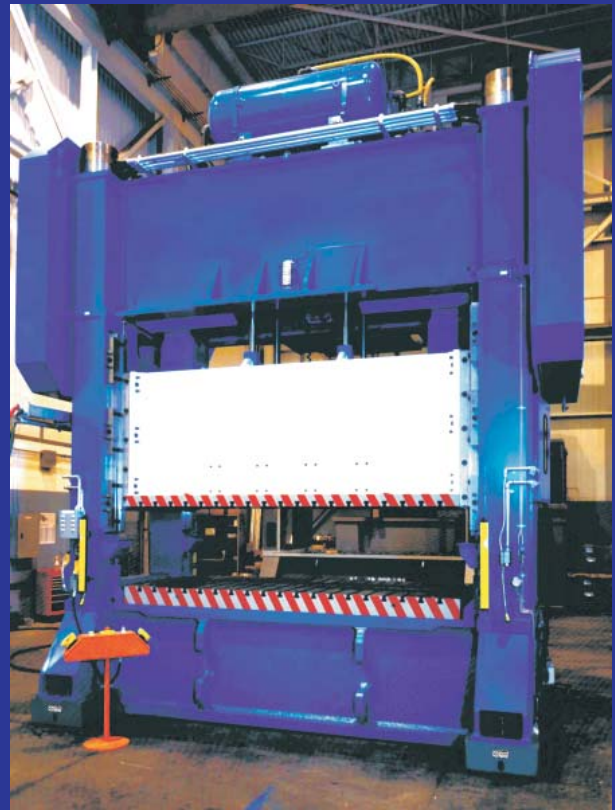

VIBRO/DYNAMICS Corporation

2443 Braga Drive, Broadview, IL 60155-3941

Telephone 708.345.2050 Fax 708.345.2225

Toll-Free 800.842.7668 in the U.S.A.

website - www.vibrodynamics.com

email - vibro@vibrodynamics.com